

# Test couplings System MINIMESS® Model CPK-MM

WIKA data sheet AC 87.02

## Applications

- Calibration service companies and service industry
- Calibrations directly on-site
- Maintenance and service facilities
- Pressure test

## Special features

- Plug-in and threaded coupling
- Integrated non-return valve enables leak-free mounting and dismounting
- Tool-free fitting of the threaded connections



Fig. left: 1620 series

Fig. right: 1215 series

## Description

### Application areas

Both connection sets contain various test couplings for adapting to WIKA calibration products to existing processes with quick-release couplings series MINIMESS® 1620 or MINIMESS® 1215. The selection and quantity is specifically configured for the various WIKA calibration products.

### Two connection sets for different systems

In practice, one often finds the test couplings 1620 series and 1215 of connections. The numbers represent the thread sizes of the test coupling connections: 1620 stands for the thread size M16 x 2 and 1215 for the thread size M12 x 1.5. For this reason, WIKA offers for each of the both systems one connection set.

### Different adapter types

The components of both sets can be divided into 4 different categories.

- Test couplings have a series-specific male thread on one side and a BSP or NPT male thread on the other side. The coupling is also fitted with a non-return valve.
- Direct connections for measuring instruments have a series-specific female thread on one side with an internal metal mandrel. The metal mandrel serves to open the non-return valves of the test couplings.
- Hose adapters have a series-specific male thread on both sides. In contrast to the couplings, these have no non-return valve integrated and are particularly suitable for the connection of two hoses.
- Measuring hoses have a series-specific female thread on both sides.

MINIMESS® is a registered trademark of Hydrotechnik GmbH in various countries.

## Test coupling “System MINIMESS®”, model CPK-MM

### Test coupling, direct connection and hose adapter

#### Material

Coupling body	Steel 1.0718 (zinc-/nickel-coated)
Metal cap	Steel 1.0718 (zinc-/nickel-coated)
Sealings	NBR (Perbunan)

#### Ambient conditions

Operating temperature	-20 ... +100 °C [-4 ... +212 °F]
-----------------------	----------------------------------

### Test couplings

Thread G	Type of sealing	Torque in Nm	Pressure (P <sub>max.</sub> ) in bar [psi]	Dimensions in mm [in]			
				H	i	ø	SW
<b>1620 series</b>							
ISO 228-G 1/8	Form F	20	400 bar [5,800 psi]	38 [1.50]	8 [0.31]	20 [0.79]	17 [0.67]
ISO 228-G 1/4	Form F	60	630 bar [9,130 psi]	36 [1.42]	10 [0.39]	20 [0.79]	19 [0.75]
1/4 NPTF	Form H	-	630 bar [9,130 psi]	33 [1.30]	16.5 [1.50]	20 [0.79]	17 [0.67]
<b>1215 series</b>							
ISO 228-G 1/8	Form F	18	400 bar [5,800 psi]	30 [1.18]	8 [0.31]	17 [0.67]	14 [0.55]
ISO 228-G 1/4	Form F	40	630 bar [9,130 psi]	29 [1.14]	10 [0.39]	17 [0.67]	19 [0.75]
1/4 NPTF	Form H	-	630 bar [9,130 psi]	26 [1.02]	15 [0.59]	17 [0.67]	14 [0.55]

### Direct connections for measuring instruments

Thread G	Pressure (P <sub>max.</sub> ) in bar [psi]	Dimensions in mm [in]	
		L	SW
<b>1620 series / 1215 series</b>			
G 1/2	630 [9,130]	17 [0.67]	27 [1.02]
1/4 NPT	630 [9,130]	-	19 [0.75]

### Hose adapters

Thread G	Pressure (P <sub>max.</sub> ) in bar [psi]	Dimensions in mm [in]	
		L	SW
<b>1620 series</b>			
M16 x 2	630 [9,130]	42 [1.65]	17 [0.67]
<b>1215 series</b>			
Fixing thread 12	630 [9,130]	29 [1.14]	14 [0.55]

### Test coupling

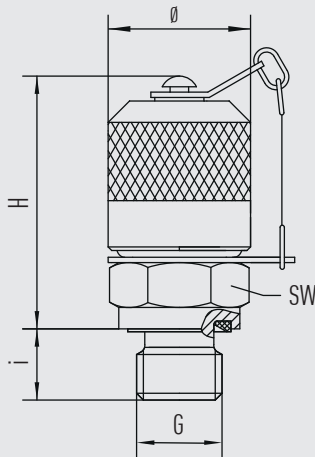

### Direct connection

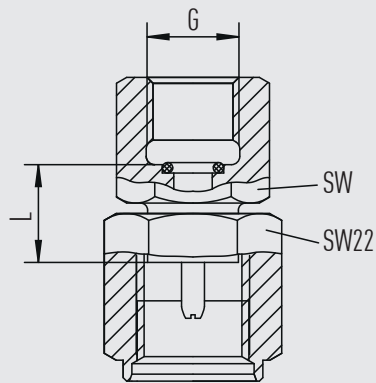

### Hose adapter

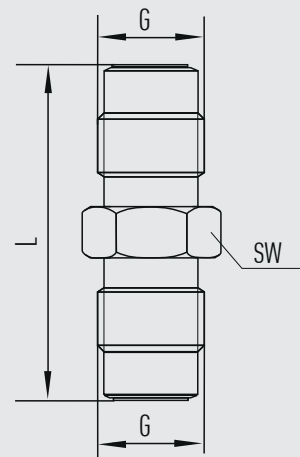

## Threaded holes and types of sealing

### Form F

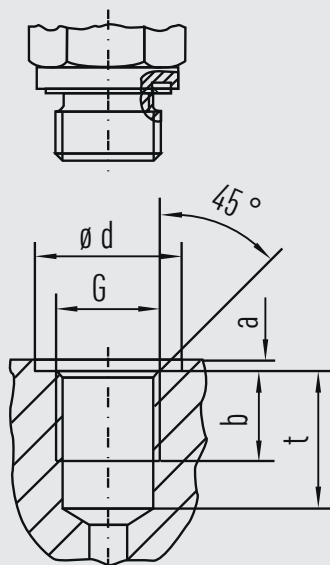

Threaded holes up to  $\varnothing d$  in accordance with DIN 3852 part 1 and part 2.  
Form X (sealing through flat gasket)

### Form H

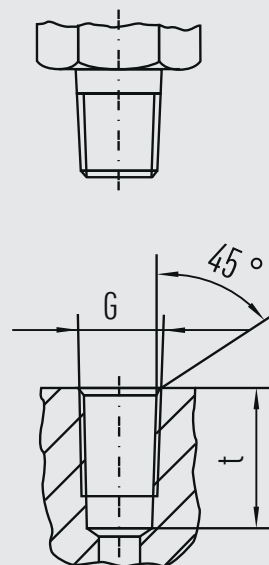

Threaded hole in accordance with ANSI/ASME B 1.20.1-1983 (self-sealing threads)

Thread G	Dimensions in mm [in]				
	Form F				Form H
	d	a	b	t	t
ISO 228-G 1/8	15.0 [0.59]	1.0 [0.04]	8.0 [0.31]	13.0 [0.51]	-
ISO 228-G 1/4	20.0 [0.79]	1.5 [0.06]	12.0 [0.47]	18.5 [0.73]	-
1/8 NPTF	-	-	-	-	12.0 [0.47]
1/4 NPTF	-	-	-	-	17.5 [0.69]

## Measuring hose

### Dimensions

Nominal width	DN 2
Internal diameter <sup>1)</sup>	2 mm [0.08 in]
Outer diameter <sup>1)</sup>	5 mm [0.20 in]
<b>Minimum bending radius</b>	20 mm [0.79 in]
<b>Application</b>	perforated hose <sup>2)</sup>
<b>Operating pressure</b>	630 bar [9,130 psi]
<b>Burst pressure</b>	1,950 bar [28,282 psi]

### Material

Inner tube	Polyamide
Pressure carrier	Polyester fibre
Jacket	Polyamide
Connections	Steel 1.0718 (zinc-/nickel-coated)

### Ambient conditions

Operating temperature	-20 ... +100 °C [-4 ... +212 °F]
Storage temperature	15 ... 25 °C [59 ... 77 °F]
Pressure utilisation <sup>3)</sup>	0 °C [32 °F] ⇒ 122 % 30 °C [86 °F] ⇒ 110 % 50 °C [122 °F] ⇒ 100 % 80 °C [176 °F] ⇒ 86 % 100 °C [212 °F] ⇒ 77 % 120 °C [248 °F] ⇒ 68 %

1) At reference conditions (20 °C - 3 K)

2) Perforated hose = jacket of hose is perforated for applications using gas

3) Calculation example:

Measuring hose DN 2/630 bar at 30 °C pressure utilisation level: 630 bar x 1.10 = 693 bar

Measuring hose DN 2/[9,130 psi] at [86 °F] pressure utilisation level: [9,130 psi x 1.10 = 10,043 psi]

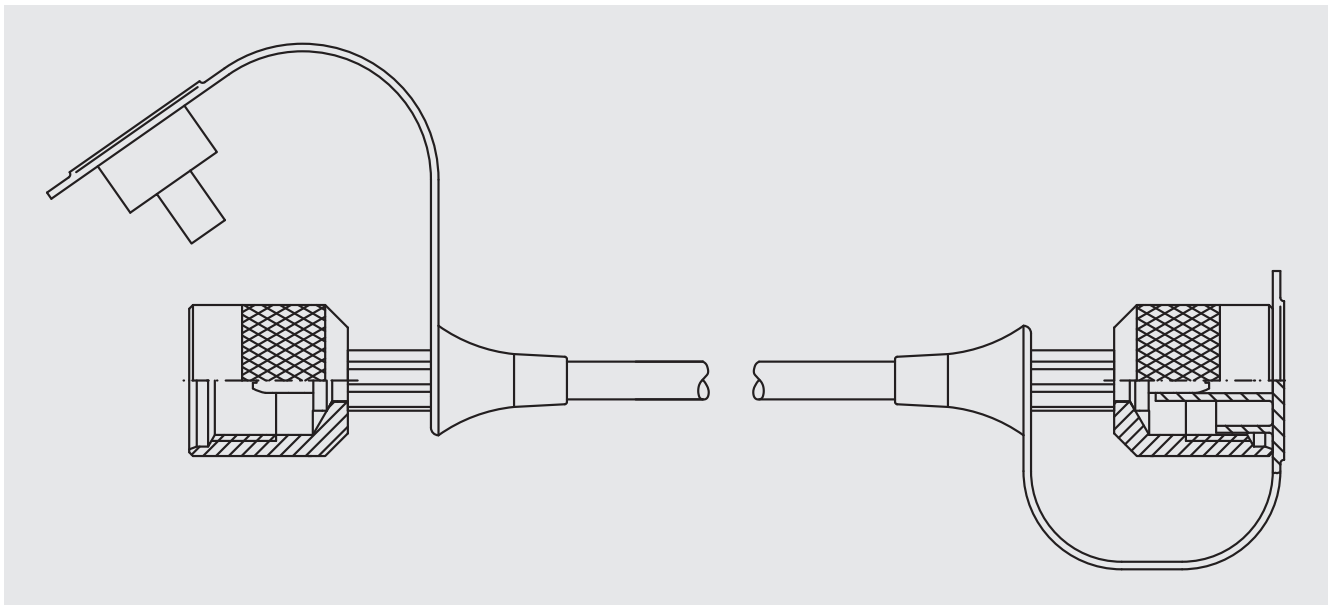

# Fields of application

## Direct connection of a pressure measuring instrument

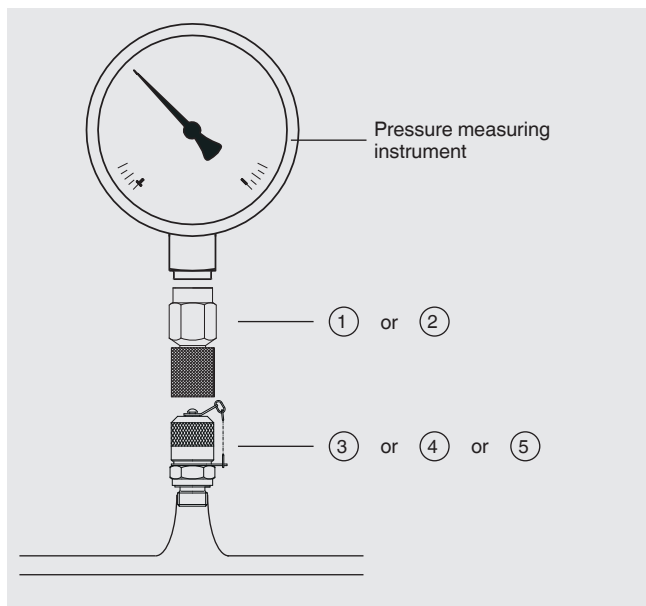

### Requirements

- Pressure measuring instrument with a G ½ or ¼ NPT male thread
- Process connection with a G ¼, G ⅜ or ¼ NPT female thread

⇒ Corresponding adapters are available in WIKA accessories.

No.:	Description
①	Direct connection for measuring instrument G ½ female thread
②	Direct connection for measuring instrument ¼ NPT female thread
③	Test coupling ISO 228-G ¼ male thread
④	Test coupling ISO 228-G ⅜ male thread
⑤	Test coupling ¼ NPTF male thread

## Connection of a pressure measuring instrument with measuring hose

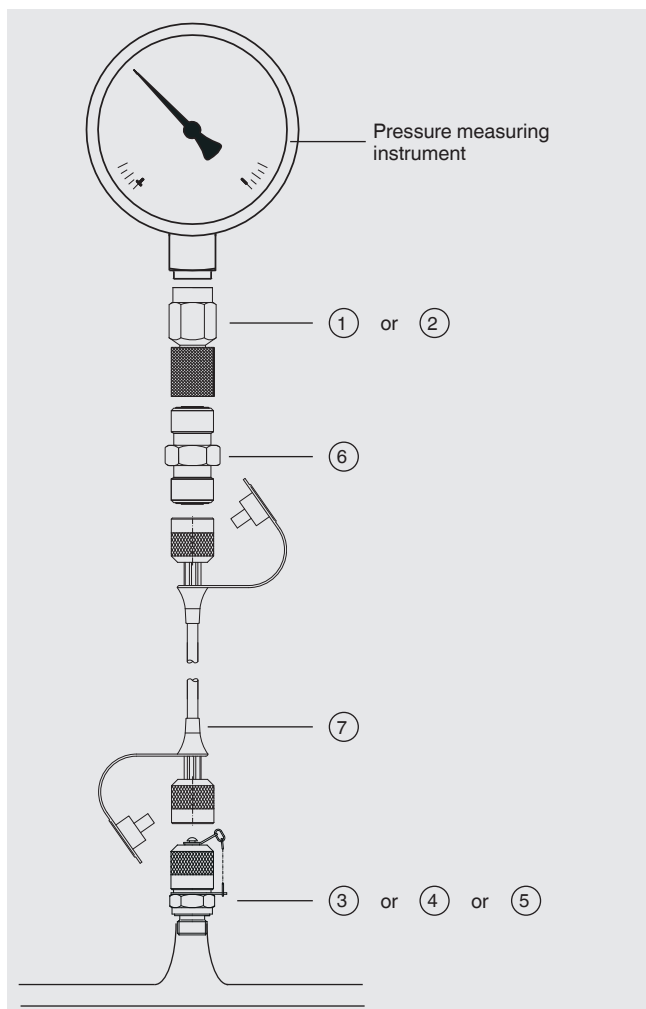

### Requirements

- Pressure measuring instrument with a G ½ or ¼ NPT male thread
- Process connection with a G ¼, G ⅜ or ¼ NPT female thread

⇒ Corresponding adapters are available in WIKA accessories.

No.:	Description
①	Direct connection for measuring instrument G ½ female thread
②	Direct connection for measuring instrument ¼ NPT female thread
③	Test coupling ISO 228-G ¼ male thread
④	Test coupling ISO 228-G ⅜ male thread
⑤	Test coupling ¼ NPTF male thread
⑥	Hose adapter (without non-return valve)
⑦	Measuring hose DN 2, length 0.5 m [19.69 in]

# Connection to a model CPH7000 process calibrator or models PASCAL ET, PASCAL 100 multi-function calibrator

## Variant 1: Connection of a test item

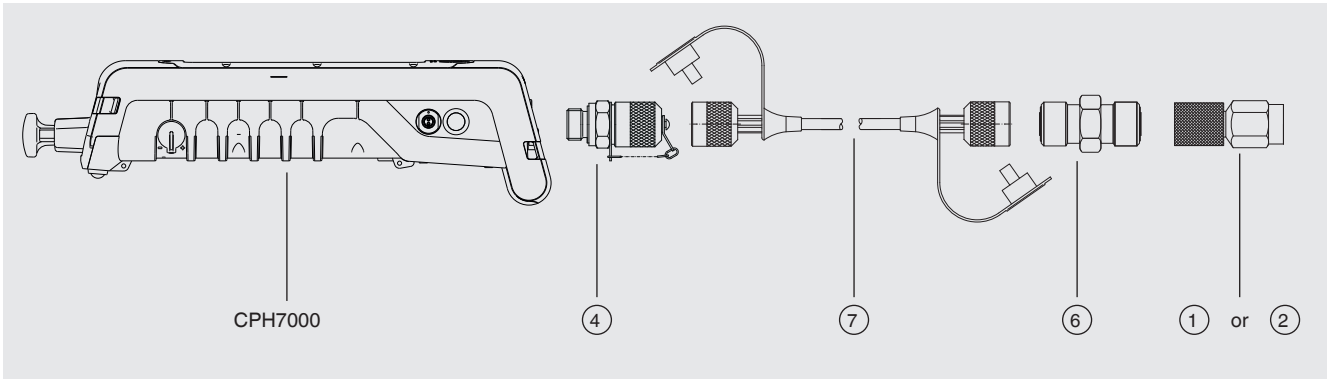

### Requirements

- Test item with a G ½ or ¼ NPT male thread.
- ⇒ Corresponding adapters are available in WIKA accessories.

No.:	Description
①	Direct connection for measuring instrument G ½ female thread
②	Direct connection for measuring instrument ¼ NPT female thread
④	Test coupling ISO 228-G ¼ male thread
⑥	Hose adapter (without non-return valve)
⑦	Measuring hose DN 2, length 0.5 m [19.69 in]

## Variant 2: Connection to a test valve or process connection

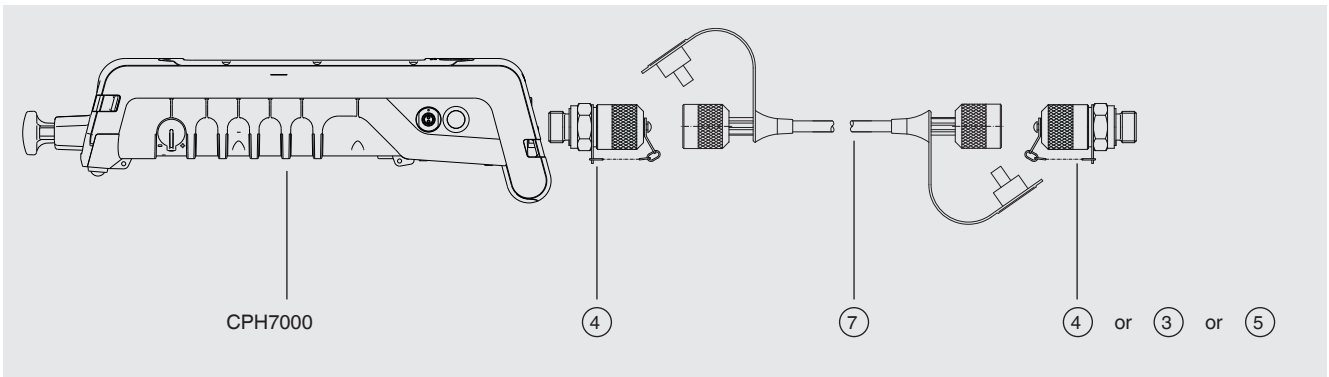

### Requirements

- Process connection with a G ¼, G ½ or ¼ NPT female thread
- ⇒ Corresponding adapters are available in WIKA accessories.

No.:	Description
③	Test coupling ISO 228-G ¼ male thread
④	Test coupling ISO 228-G ¼ male thread
⑤	Test coupling ¼ NPTF male thread
⑦	Measuring hose DN 2, length 0.5 m [19.69 in]

## Connection of a pressure controller, model CPC from Mensor

### Requirements

- The pressure connection adapter 7/16" – 20 F SAE male thread to G 1/8 female thread must be ordered separately.

⇒ Corresponding adapters are available in WIKA accessories.

### Variant 1: Connection of a test item

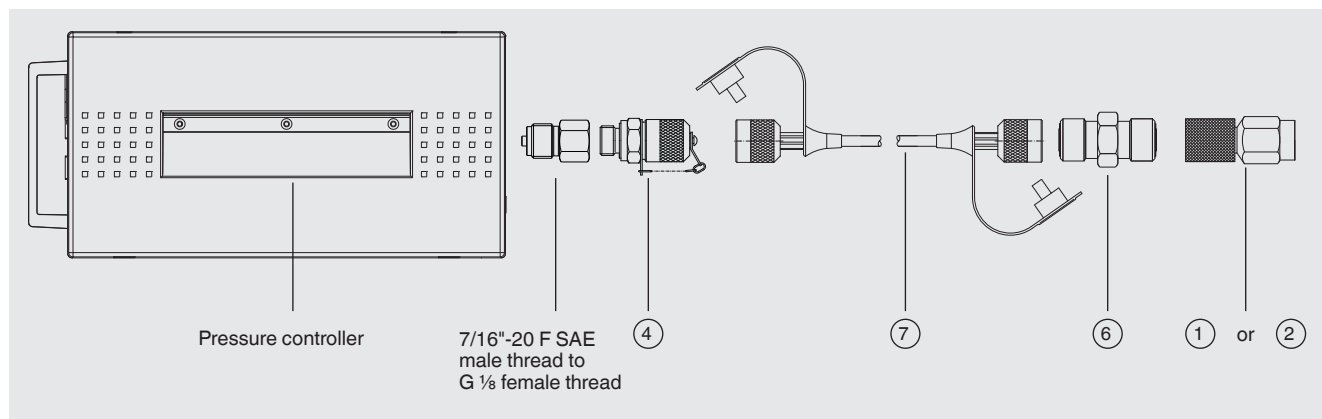

No.:	Description
①	Direct connection for measuring instrument G 1/2 female thread
②	Direct connection for measuring instrument 1/4 NPT female thread
④	Test coupling ISO 228-G 1/8 male thread
⑥	Hose adapter (without non-return valve)
⑦	Measuring hose DN 2, length 0.5 m [19.69 in]

### Variant 2: Connection of the pressure controller to a test valve or process connection

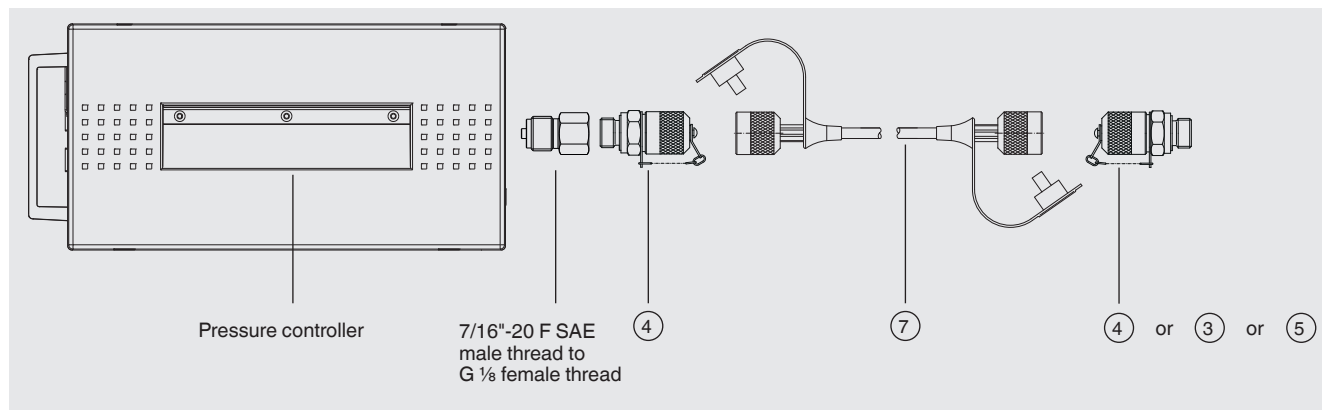

No.:	Description
③	Test coupling ISO 228-G 1/4 male thread
④	Test coupling ISO 228-G 1/8 male thread
⑤	Test coupling 1/4 NPTF male thread
⑦	Measuring hose DN 2, length 0.5 m [19.69 in]

## Connection to the pneumatic hand test pump, model CPP7-H

### Requirements

- The T-connection adapter is a part of the scope of delivery of the CPP7-H
- If a measuring hose is connected to each G 1/8 female thread of the T-connection adapter, further components are necessary!

⇒ Corresponding adapters are available in WIKA accessories.

### Variant 1: Connection of a test item

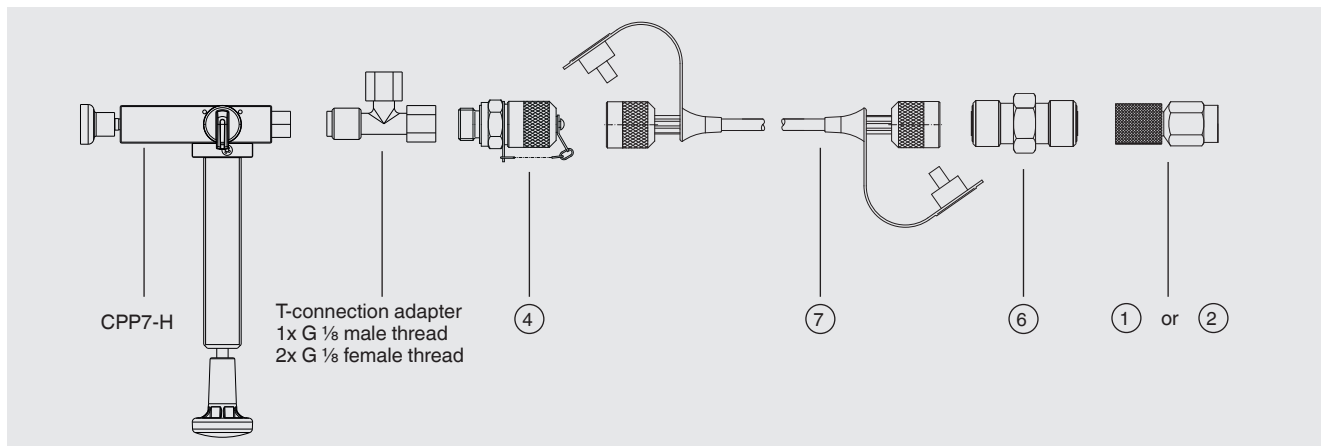

No.:	Description
①	Direct connection for measuring instrument G 1/2 female thread
②	Direct connection for measuring instrument 1/4 NPT female thread
④	Test coupling ISO 228-G 1/8 male thread
⑥	Hose adapter (without non-return valve)
⑦	Measuring hose DN 2, length 0.5 m [19.69 in]

### Variant 2: Connection of the model CPP7-H of the pneumatic hand test pump to a test valve or process connection

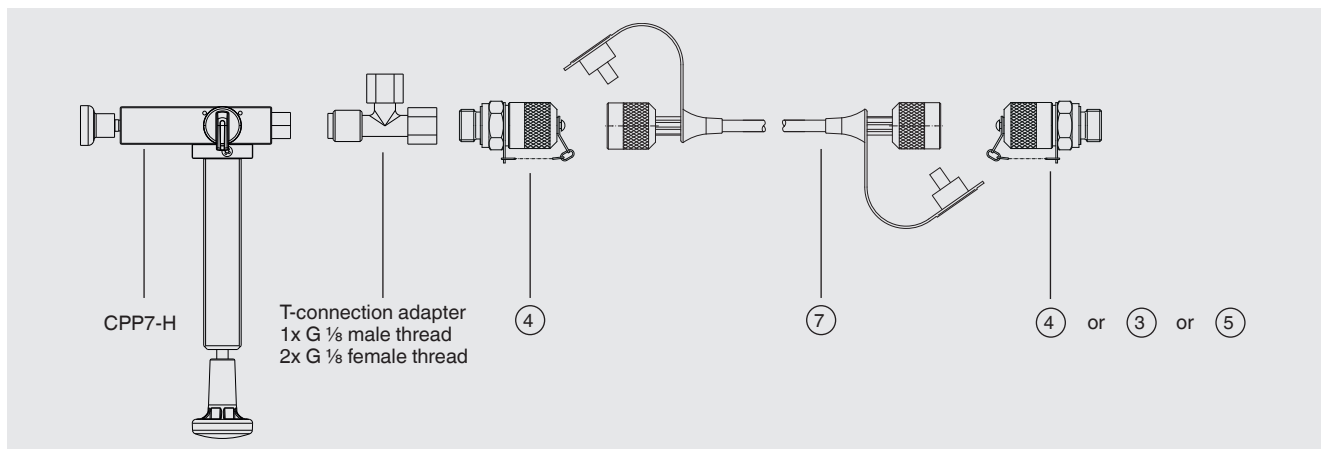

No.:	Description
③	Test coupling ISO 228-G 1/4 male thread
④	Test coupling ISO 228-G 1/8 male thread
⑤	Test coupling 1/4 NPTF male thread
⑦	Measuring hose DN 2, length 0.5 m [19.69 in]



## Connection to the pneumatic hand test pump, model CPP30

### Variant 1: Connection of a test item

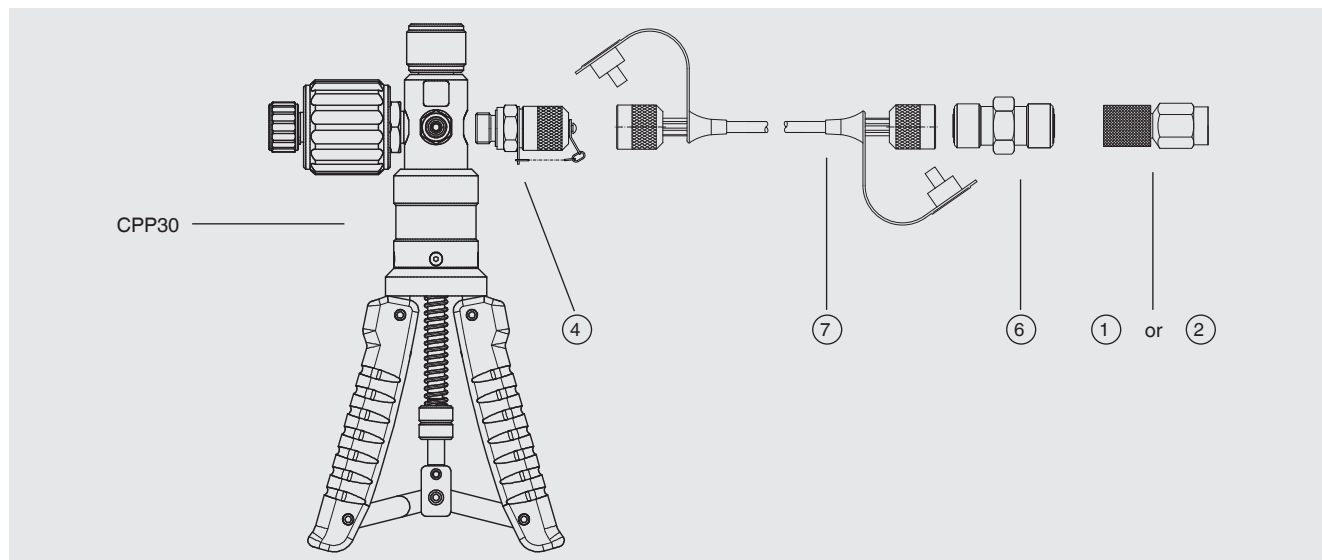

No.:	Description
①	Direct connection for measuring instrument G ½ female thread
②	Direct connection for measuring instrument ¼ NPT female thread
④	Test coupling ISO 228-G ⅜ male thread
⑥	Hose adapter (without non-return valve)
⑦	Measuring hose DN 2, length 0.5 m [19.69 in]

### Variant 2: Connection of the model CPP30 of the pneumatic hand test pump to a test valve or process connection

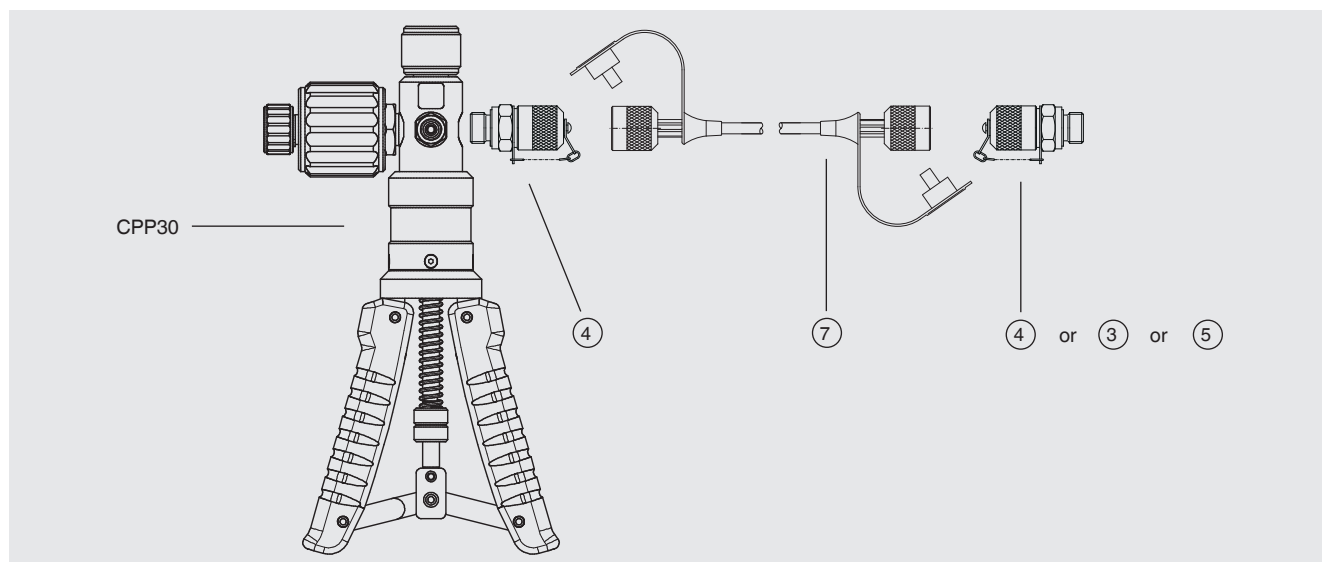

No.:	Description
③	Test coupling ISO 228-G ¼ male thread
④	Test coupling ISO 228-G ⅜ male thread
⑤	Test coupling ¼ NPTF male thread
⑦	Measuring hose DN 2, length 0.5 m [19.69 in]

## Accessories

Depending upon which adapter set is used, the following parts are also available individually.

### For 1620 series

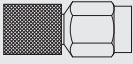
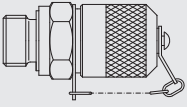
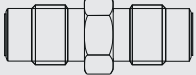
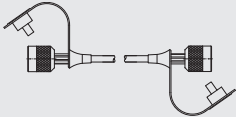

Description	Order number	
	Direct connection for measuring instrument G 1/2 female thread	9072306
	Direct connection for measuring instrument 1/4 NPT female thread	14340206
	Test coupling ISO 228-G 1/4 male thread	9072284
	Test coupling ISO 228-G 1/8 male thread	14340208
	Test coupling 1/4 NPTF male thread	14340207
	Hose adapter (without non-return valve)	14340209
	Measuring hose DN 2, length 0.5 m [19.69 in]	14340220
	Measuring hose DN 2, length 1 m [39.37 in]	11403306
	Measuring hose DN 2, length 2 m [78.74 in]	14349940

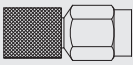
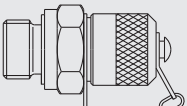
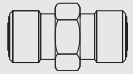
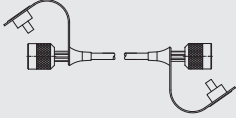
### For 1215 series

Description	Order number	
	Direct connection for measuring instrument G 1/2 female thread	14340210
	Direct connection for measuring instrument 1/4 NPT female thread	14340215
	Test coupling ISO 228-G 1/4 male thread	14340211
	Test coupling ISO 228-G 1/8 male thread	14340218
	Test coupling 1/4 NPTF male thread	14340217
	Hose adapter (without non-return valve)	14340219
	Measuring hose DN 2, length 0.5 m [19.69 in]	14340222
	Measuring hose DN 2, length 1 m [39.37 in]	14349976
	Measuring hose DN 2, length 2 m [78.74 in]	14349986

Other connection adapters are available on request.

## Scope of delivery

Description	Order code
 <p><b>1620 series adapter set in storage case</b>            Consisting of:            1x Direct connection G ½ female thread; P<sub>max</sub> 400 bar [5,800 psi]            1x Direct connection ¼ NPT female thread; P<sub>max</sub> 630 bar [9,130 psi]            1x Test coupling ISO 228-G ¼ male thread; P<sub>max</sub> 630 bar [9,130 psi]            2x Test coupling ISO 228-G ⅜ male thread; P<sub>max</sub> 400 bar [5,800 psi]            1x Coupling ¼ NPTF male thread; P<sub>max</sub> 630 bar [9,130 psi]            1x Hose adapter (without non-return valve); P<sub>max</sub> 630 bar [9,130 psi]            1x Measuring hose DN 2, length 0.5 m [19.69 in]; P<sub>max</sub> 630 bar [9,130 psi]</p>	<b>CPK-MM-</b>  <b>-1SZ-</b>
 <p><b>1215 series adapter set in storage case</b>            Consisting of:            1x Direct connection G ½ female thread; P<sub>max</sub> 400 bar [5,800 psi]            1x Direct connection ¼ NPT female thread; P<sub>max</sub> 630 bar [9,130 psi]            1x Test coupling ISO 228-G ¼ male thread; P<sub>max</sub> 630 bar [9,130 psi]            2x Test coupling ISO 228-G ⅜ male thread; P<sub>max</sub> 400 bar [5,800 psi]            1x Test coupling ¼ NPTF male thread; P<sub>max</sub> 630 bar [9,130 psi]            1x Hose adapter (without non-return valve); P<sub>max</sub> 630 bar [9,130 psi]            1x Measuring hose DN 2, length 0.5 m [19.69 in]; P<sub>max</sub> 630 bar [9,130 psi]</p>	<b>-2SZ-</b>
<b>Ordering information for your enquiry:</b>	
<b>1. Order code: CPK-MM</b> <b>2. Option:</b>	↓ [   ]

## Ordering information

Series / Connection type / Additional ordering information

© 09/2019 WIKA Alexander Wiegand SE & Co. KG, all rights reserved.  
 The specifications given in this document represent the state of engineering at the time of publishing.  
 We reserve the right to make modifications to the specifications and materials.

